

ABS | Upright Cabinets

FREEZER UPRIGHT ▶ INOX

QNX 200

DETAILS

Digital Thermostat

Fixed evaporator shelves

Lock fitted as standard

The items can be supplied either with adjustable feet or lockable castor



GENERAL FEATURES

- 200 Lt. Freezer upright
- S/S external cabinet, thermoformed internally
- Static cooling: fixed evaporator shelves (N.3 Layers)
- Manual Defrost
- Foaming Agent Cyclopentane (55mm per side)
- Heated body frame (Hot pipe system)
- Digital Thermostat
- Opening door alarm
- Removable Gasket
- Reversible door
- Doors lock fitted as standard
- N.2 Adjustable feet + N.2 Rollers at the back
- HIGH S/S Adjustable feet or Lockable castor as optional
- Energy efficiency class: -

TECHNICAL SPECIFICATIONS

Capacity	200 L
Temperature	-20°C - -15°C
Consumption	1.18 kWh/24h
Rated Power	130 W
Noise level	40 dB(A)
Net Weight	36 Kg
Gross Weight	40 Kg
External Dimensions (WxDxH mm)	600x637x835
Internal Dimensions (WxDxH mm)	439x453x660
Packaging dimensions (WxDxH mm)	640x675x880
Loading quantities 20'/40'/40'HQ	54/108/162

PRODUCT DIMENSIONS

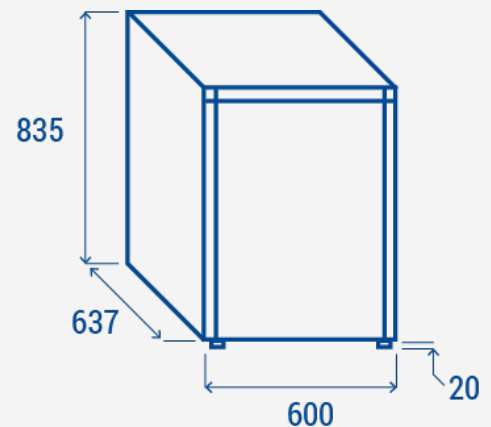

CERTIFICATION

CE RoHS

